

Metallized Polypropylene Film AC Film Capacitors

FAD Series - 230 ~ 850VAC (Cylindrical Aluminum Can, Three Phase)



Overview

The FAD series capacitors are designed for PFC system or filtering harmonics at the AC output of large inverter system. The FAD series capacitor consists of metallized polypropylene film, enclosed in cylindrical Al case and filled with soft PU resin.

Applications

Widely used in PFC, AC Filtering and LCL System

Features

- Double safety protection
 - Self-healing property
 - Overpressure disconnecter device
- 3 phases in one case, delta connection
- High reliability
- Oil type with good thermal dissipation



Approvals

Marking	Specification	File Number
	Components	E500536

Marking

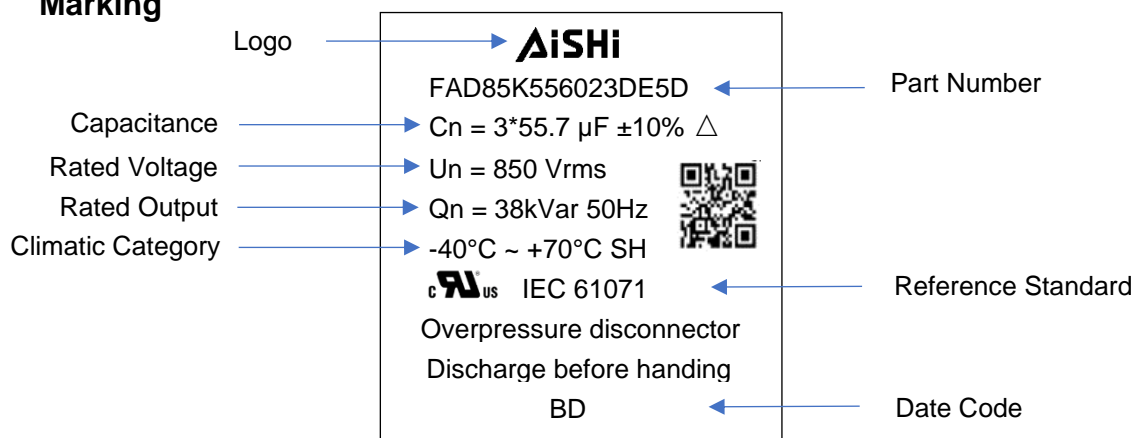

Manufacturing Date Code

Year	Code	Month	Code
2018	A	Jan	1
2019	B	Feb	2
2020	C	Mar	3
2021	D	Apr	4
2022	E	May	5
2023	F	Jun	6

Year	Code	Month	Code
2024	G	Jul	7
2025	H	Aug	8
2026	J	Sep	9
2027	K	Oct	A
2028	L	Nov	N
2029	M	Dec	D

Metallized Polypropylene Film AC Film Capacitors

FAD Series - 230 ~ 850VAC (Cylindrical Aluminum Can, Three Phase)



Part Number System

F	AD	85	K	556	023	DE5	D
Capacitor Type	Series	Voltage (VDC)	Tolerance	Capacitance (pF)	Size Code	Terminal Code	Bottom Stud Code
F = Film	AC Filtering, Al Can Three Phase, Metallized PP Film	230 = 23 400 = 40 440 = 44 480 = 48 525 = 52 660 = 66 690 = 69 760 = 76 850 = 85	J = ±5% K = ±10%	First two digits = significant figures. Third digit = Number of zeros.	Refer to Dimension Table	Refer to Terminal Code Table	Refer to Bottom Stud Code Table

Terminal Code

Digit One (Lead/Terminal Type)		Digit Two (Terminal Space)		Digit Three (Terminal Size)	
Three Phase Screw	D	15	E	M5	5

Bottom Stud Code

Bottom Stud	
Bottom M12*16	D
No Bottom Stud	E

Metallized Polypropylene Film AC Film Capacitors

FAD Series - 230 ~ 850VAC (Cylindrical Aluminum Can, Three Phase)

Dimension (mm)

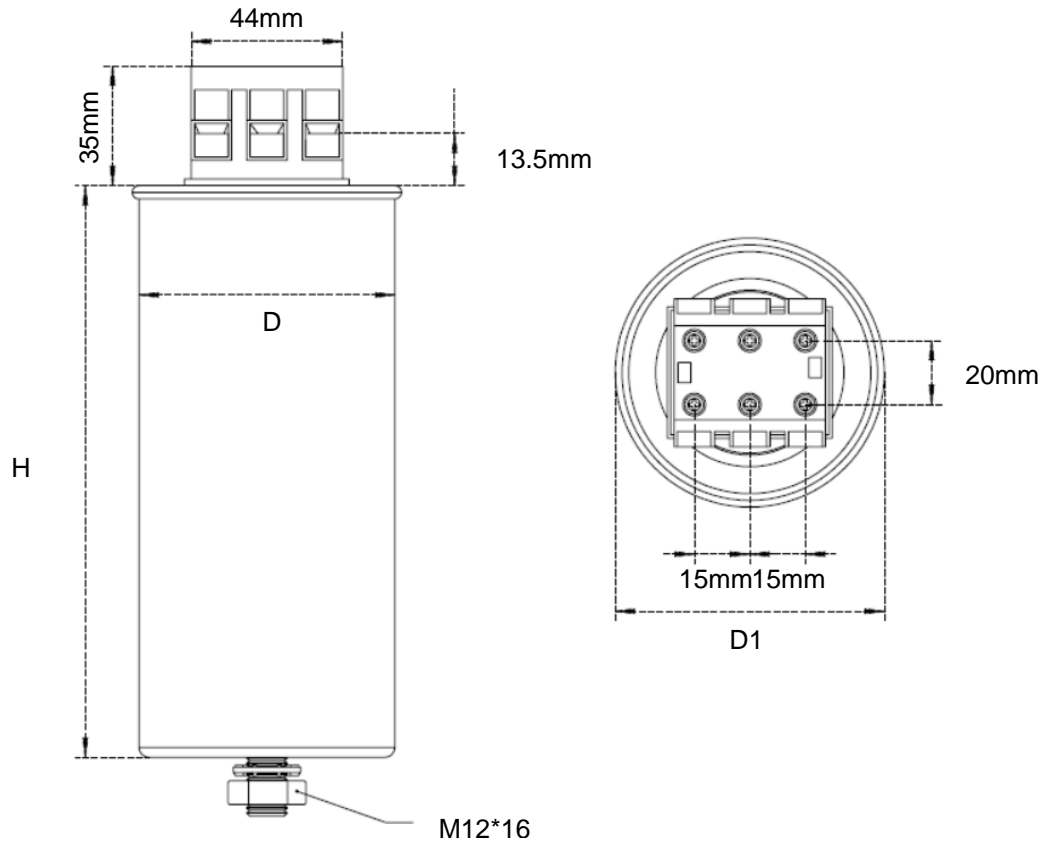

Dimension (mm)

Case Code	D ± 1mm		D1 ± 1mm		H ± 2mm	
	mm	inch	mm	inch	mm	inch
316	76	(2.99)	80	(3.15)	164	(6.46)
516	86	(3.39)	90	(3.54)	160	(6.30)
520	86	(3.39)	90	(3.54)	200	(7.87)
523	86	(3.39)	90	(3.54)	230	(9.06)
527	86	(3.39)	90	(3.54)	275	(10.83)
535	86	(3.39)	90	(3.54)	350	(13.78)
623	96	(3.78)	101	(3.98)	230	(9.06)
916	116	(4.57)	121	(4.76)	160	(6.30)
920	116	(4.57)	121	(4.76)	200	(7.87)
923	116	(4.57)	121	(4.76)	230	(9.06)
927	116	(4.57)	121	(4.76)	275	(10.83)
020	136	(5.35)	142	(5.59)	200	(7.87)
023	136	(5.35)	142	(5.59)	230	(9.06)

Metallized Polypropylene Film AC Film Capacitors

FAD Series - 230 ~ 850VAC (Cylindrical Aluminum Can, Three Phase)



Rating and Part Number

Vac	Cap Value μF	OD±1		H±2		Output Kvar @50Hz	Irms at 40°C A	Surge Current A	dv/dt (Max) V/us	Pkg Qty pcs	Part Number
		mm	inch	mm	inch						
230	3 x 200.6	86	(3.39)	275	(10.83)	10.0	25.1	5021	25	8	FAD23K207527DE5D
230	3 x 200.6	116	(4.57)	160	(6.30)	10.0	25.1	5021	25	5	FAD23K207916DE5D
230	3 x 250.7	86	(3.39)	275	(10.83)	12.5	31.4	6276	25	8	FAD23K257527DE5D
230	3 x 250.7	116	(4.57)	200	(7.87)	12.5	31.4	6276	25	5	FAD23K257920DE5D
230	3 x 300.9	86	(3.39)	350	(13.78)	15.0	37.7	7531	25	8	FAD23K307535DE5D
230	3 x 300.9	116	(4.57)	200	(7.87)	15.0	37.7	7531	25	5	FAD23K307920DE5D
230	3 x 335.0	116	(4.57)	230	(9.06)	16.7	41.9	8384	25	5	FAD23K337923DE5D
400	3 x 66.3	86	(3.39)	200	(7.87)	10.0	14.4	2887	44	8	FAD40K666520DE5D
400	3 x 82.9	86	(3.39)	200	(7.87)	12.5	18.0	3609	44	8	FAD40K836520DE5D
400	3 x 99.5	86	(3.39)	275	(10.83)	15.0	21.7	4330	44	8	FAD40K107527DE5D
400	3x110.7	86	(3.39)	275	(10.83)	16.7	24.1	4821	44	8	FAD40K117527DE5D
400	3x110.7	116	(4.57)	160	(6.30)	16.7	24.1	4821	44	5	FAD40K117916DE5D
400	3x132.6	86	(3.39)	275	(10.83)	20.0	28.9	5774	44	8	FAD40K137527DE5D
400	3x132.6	116	(4.57)	200	(7.87)	20.0	28.9	5774	44	5	FAD40K137920DE5D
400	3x165.8	86	(3.39)	350	(13.78)	25.0	36.1	7217	44	8	FAD40K167535DE5D
400	3x165.8	116	(4.57)	200	(7.87)	25.0	36.1	7217	44	5	FAD40K167920DE5D
400	3x198.9	136	(5.35)	200	(7.87)	30.0	43.3	8661	44	2	FAD40K207020DE5D
440	3x46	86	(3.39)	160	(6.30)	8.3	10.9	2178	48	8	FAD44K466516DE5D
440	3 x 68.5	86	(3.39)	200	(7.87)	12.5	16.4	3280	48	8	FAD44K696520DE5D
440	3 x 82.2	86	(3.39)	200	(7.87)	15.0	19.7	3937	48	8	FAD44K836520DE5D
440	3x109.0	86	(3.39)	275	(10.83)	20.0	26.2	5249	48	8	FAD44K117527DE5D
440	3x109.0	116	(4.57)	160	(6.30)	20.0	26.2	5249	48	5	FAD44K117916DE5D
440	3x123.3	86	(3.39)	275	(10.83)	22.5	29.5	5905	48	8	FAD44K127527DE5D
440	3x123.3	116	(4.57)	200	(7.87)	22.5	29.5	5905	48	5	FAD44K127920DE5D
440	3x137.0	116	(4.57)	200	(7.87)	25.0	32.8	6561	48	5	FAD44K147920DE5D
440	3x156	116	(4.57)	200	(7.87)	28.1	36.9	7375	48	5	FAD44K157920DE5D
440	3x164.4	86	(3.39)	350	(13.78)	30.0	39.4	7873	48	8	FAD44K167535DE5D
440	3x164.4	116	(4.57)	200	(7.87)	30.0	39.4	7873	48	5	FAD44K167920DE5D
480	3x40	86	(3.39)	200	(7.87)	8.7	10.5	2093	52	8	FAD48K406520DE5D
480	3x60	86	(3.39)	275	(10.83)	13.0	15.6	3127	52	8	FAD48K606527DE5D
480	3x80	116	(4.57)	200	(7.87)	17.4	20.9	4186	52	5	FAD48K806920DE5D
480	3x120	116	(4.57)	275	(10.83)	26.0	31.3	6255	52	5	FAD48K127927DE5D
525	3 x 38.5	86	(3.39)	200	(7.87)	10.0	11.0	2199	57	8	FAD52K396520DE5D
525	3x48.1	86	(3.39)	200	(7.87)	12.5	13.7	2749	57	8	FAD52K486520DE5D
525	3x58	86	(3.39)	230	(9.06)	15.0	16.5	3299	57	8	FAD52K586523DE5D
525	3 x 77.0	86	(3.39)	275	(10.83)	20.0	22.0	4399	57	8	FAD52K776527DE5D
525	3*96	86	(3.39)	350	(13.78)	25.0	27.5	5499	57	8	FAD52K966535DE5D
525	3*96	116	(4.57)	200	(7.87)	25.0	27.5	5499	57	5	FAD52K966920DE5D
525	3*115.4	136	(5.35)	200	(7.87)	30.0	33.0	6598	57	2	FAD52K117020DE5D
660	3 x 20.3	86	(3.39)	200	(7.87)	8.3	7.3	1457	72	8	FAD66K206520DE5D
660	3 x 24.4	86	(3.39)	200	(7.87)	10.0	8.7	1750	72	8	FAD66K256520DE5D
660	3 x 30.4	86	(3.39)	230	(9.06)	12.5	10.9	2187	72	8	FAD66K306523DE5D
660	3 x 36.5	96	(3.78)	230	(9.06)	15.0	13.1	2624	72	6	FAD66K366623DE5D
660	3 x 48.7	86	(3.39)	350	(13.78)	20.0	17.5	3499	72	8	FAD66K496535DE5D
690	3 x 27.9	86	(3.39)	230	(9.06)	12.5	10.5	2092	75	8	FAD69K286523DE5D
690	3 x 33.4	96	(3.78)	230	(9.06)	15.0	12.6	2510	75	6	FAD69K336623DE5D
690	3 x 44.6	86	(3.39)	350	(13.78)	20.0	16.7	3347	75	8	FAD69K456535DE5D
690	3 x 55.7	86	(3.39)	350	(13.78)	25.0	20.9	4184	75	8	FAD69K566535DE5D

Metallized Polypropylene Film AC Film Capacitors

FAD Series - 230 ~ 850VAC (Cylindrical Aluminum Can, Three Phase)



Rating and Part Number

Vac	Cap Value μF	OD±1		H±2		Output Kvar @50Hz	I _{rms} at 40°C A	Surge Current A	dv/dt (Max) V/us	Pkg Qty pcs	Part Number
		mm	inch	mm	inch						
850	3X8	76	(2.99)	164	6.46	5.4	20.0	960	120	12	FAD85K805316DE5D
850	3X16	86	(3.39)	200	7.87	10.9	25.0	1920	120	8	FAD85K166520DE5D
850	3X25	96	(3.78)	230	9.06	17.0	40.0	2500	100	6	FAD85K256623DE5D
850	3X37.5	116	(4.57)	230	9.06	25.5	45.0	3800	100	5	FAD85K376923DE5D
850	3X41.5	116	(4.57)	230	9.06	28.2	50.0	4200	100	5	FAD85K416923DE5D
850	3X49	136	(5.35)	230	9.06	33.3	50.0	4900	100	2	FAD85K496023DE5D
850	3X55.8	136	(5.35)	230	9.06	37.9	50.0	5600	100	2	FAD85K556023DE5D

General Technical Data

Applications	AC Filtering
Dielectric	Polypropylene Metallized Film
Reference Standard	IEC 61071
Climatic Category	40/85/56 IEC 60068-1
Operating Temperature Range	-40°C ~ +85°C
Storage Temperature	-40°C ~ +85°C
Storage Conditions	Storage time: ≤24months from the date marked on the label package Average relative humidity per year ≤70% RH≤85% for 30 days randomly distributed throughout the year Dew is absent Temperature: -40°C ~ +85°C
Storage Life	Product that passed less than 2 years from production, No need reconfirmation
RoHS Compliance	Compliant with the restricted substance requirement of Directive 2011/65/EU
Maximum Torque (Nm)	M5 = 3Nm M12 = 15Nm (Bottom Stud)

Electric Clearance and Creepage



Can Diameter	Distance terminal to terminal		Distance terminal to case	
	Creepage	Clearance	Creepage	Clearance
76	15	NA	15	10
86	15	NA	15	10
116	15	NA	15	10
136	15	NA	15	10

Metallized Polypropylene Film AC Film Capacitors

FAD Series - 230 ~ 850VAC (Cylindrical Aluminum Can, Three Phase)

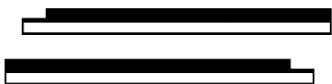

Construction

Metallized Film	OPP & Al/Zn	
Metal Sprayed	Zn	
Connection Electrode	Tin coated Cu	
Aluminum Case	Al can with stud	
Top Cover	Al can with three phase terminals	
Filling	Soft resin (Non-PCB)	
Terminal	Tinned brass	
Film Construction	<p style="text-align: center;">Mono Structure</p> 	<p style="text-align: center;">Internal Series Connection</p> 

Electrical Characteristics

Voltage Range	230Vac ~ 850Vac
Capacitance Range	3*8uF ~ 3*335uF
Capacitance Tolerance	±5% or ±10% at +25°C
Capacitance	Measuring Frequency at 1kHz Measuring Voltage: 1±0.2V
Standard Atmospheric Conditions for Static Test	Ambient temperature 15°C to 35°C (If there is any doubt on the results, the measurements shall be made at +20 +/- 5°C) Relative humidity 45% to 75% (If there is any doubt on the results, the measurements shall be made at 60% to 70 %.) Air pressure 86 kPa to 106 kPa.
Visual examination, Marking (Non-Destructive)	Appearance: no remarkable abnormality
Voltage Between Terminals U_{TT}	2.15 x RMS rated voltage for 10s
Voltage Between Terminals and Case U_{TC}	4KVac 50Hz for 10s
Dielectric Dissipation Factor $Tg\delta_0$	$\leq 2 \times 10^{-4}$
Dissipation factor	≤ 0.0020 at 100Hz
Insulation Resistance	$R_{is} \times C \geq 5,000s$ at 100VDC 1minute at +25°C
Surge Current (Is)	200 * I rated
Hot-Spot	$\leq 85^\circ C$
Life Expectancy	$\geq 100,000$ hours at rated voltage and 70°C
Failure Rate	$\leq 100FIT$
Max. Altitude	4000m, when above 2000m current derating as per 1.35%/100m

Environmental Test

High Temperature Loading	Test Conditions: Testing method per IEC 61071 Test Temperature: +70 +/-2 °C. Apply 125% of rated voltage for 1,000 +24/-0 hours. Duration: 500 hours 1000 charges and discharges At 1.3 x I peak (maximum respective peak current in continuous operation) Performance: Capacitance Change Rate ($\Delta C/C$): $\leq \pm 3\%$ Insulation Resistance: $\geq 50\%$ of initial limit
--------------------------	---

Expected Life Curve

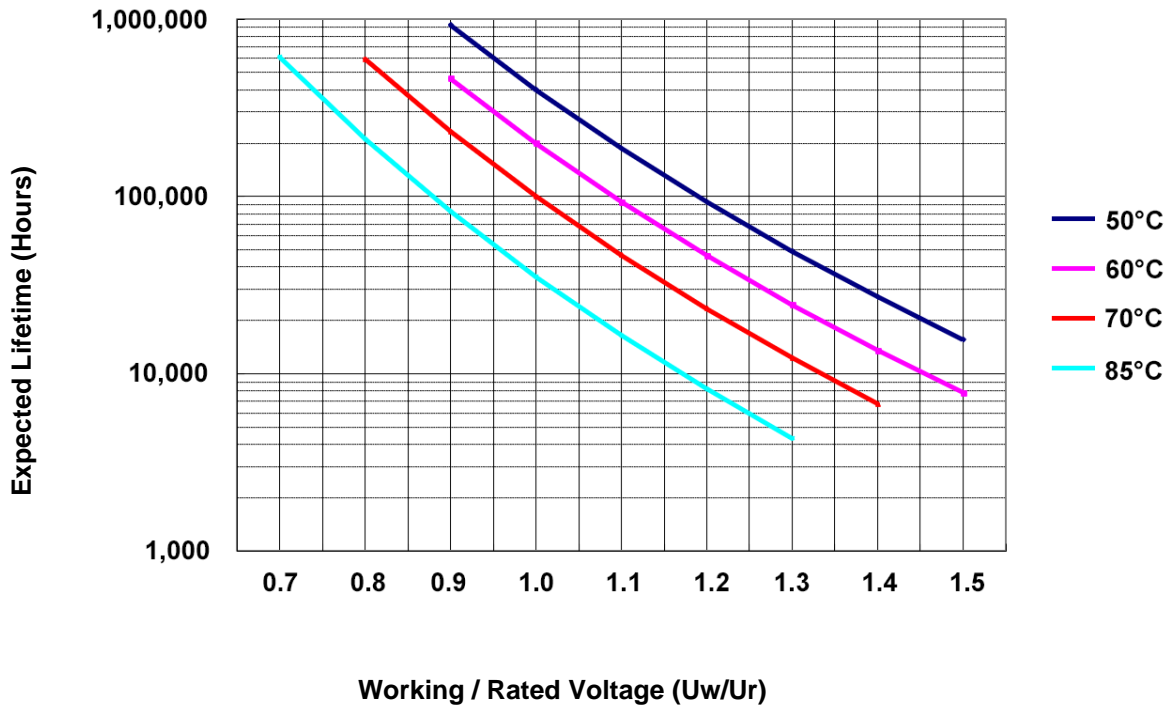

Packaging Information

Capacitors are well protected by foams. And then are packaged in the cartons.

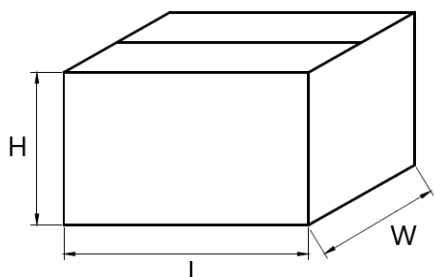

Table 1 carton dimensions

Carton No.	L (mm)	W (mm)	H (mm)
1	375	285	235
2	375	285	300
3	375	285	330
4	375	285	365
5	375	285	265

According to the capacitor’s diameter, every carton contains capacitors as per the following Table 2.

Table 2 Capacitor quantity of each carton

Capacitor Diameter (mm)	Quantity (pcs)
76	12
86	8
96	6
116	5
136	2

Cautions and Warnings

- Don't exceed the upper category temperature.
- For longtime storage, maximum relative humidity 80%, no dew allowed on the capacitor.
- Do not use or store capacitor in corrosive atmosphere, in the dusty environment's regular maintenance and cleaning especially of the terminals is required to avoid conductive path between terminal / or terminal and ground.
- Don't apply any mechanical stress to the capacitor terminals, and avoid any compressive, tensile or flexural stress.
- Avoid overload of the capacitors
- Do not have unlimited service life expectancy, the max service life expectancy may vary depending on the application the capacitor is used in.

Disclaimer

All product, product specifications and data in this datasheet are subject to change without notice to improve reliability, function or design or otherwise. The customer is responsible for checking and verifying the extent to which the Information contained in this publication is applicable to an order at the time the order is placed. All Information given herein is believed to be accurate and reliable, but it is presented without guarantee, warranty, or responsibility of any kind, expressed or implied.

In individual cases, a malfunction of electronic components or failure before the end of their usual service life cannot be completely ruled out in the current state of the art, even if they are operated as specified. In customer application requiring a very high level of operational safety and especially in customer applications in which the malfunction or failure of an electronic component could endanger human life or health (e.g. in accident prevention or lifesaving systems), it must therefore be ensured by means of suitable design of the customer application or other action taken by the customer (e.g. installation of protective circuitry or redundancy) that no injury or damage is sustained by third parties in the event of malfunction or failure of an electronic component.

We continue efforts to improve our products. Therefore, the products described in this publication may change from time to time. The same is true of the corresponding product specifications. Please check therefore to what extent product descriptions and specifications contained in this publication are still applicable before or when you place an order. We also reserve the right to discontinue production and delivery of products. Consequently, we cannot guarantee that all products named in this publication will always be available.

No license, express or implied, by estoppel or otherwise, to any intellectual property rights is granted by this document or by any conduct of Aishi. Product names and markings noted herein may be trademarks of their respective owners.